



Automotive
Energy & Power Analysis
Aerospace & Defense
Transportation
General Test & Measurement

DEWE-EPAD2/CPAD2 modules

Technical reference manual



ISO9001

Re-inventing Data Acquisition



Copyright © DEWETRON elektronische Messgeraete Ges.m.b.H.

This document contains information which is protected by copyright. All rights are reserved. Reproduction, adaptation, or translation without prior written permission is prohibited, except as allowed under the copyright laws.

All trademarks and registered trademarks are acknowledged to be the property of their owners.

Content

General Information, Safety Instructions	5
Warranty Information	5
Support	5
Printing History.....	5
Safety symbols in the manual	6
Safety instructions for all DEWETRON systems	7
Environmental Considerations	8
General module information	9
Calibration information	9
General module specifications	9
EPAD2/CPAD2-TH8-x Module	11
Module specifications	11
Push button	13
Connection	13
Programming information	13
EPAD2/CPAD2-V8 Module	15
Module specifications	15
Push button	17
Connection	17
Programming information	18
EPAD2/CPAD2-RTD8 Module	19
Module specifications	19
Push button	21
Connection	21
Programming information	22
EPAD2/CPAD2-TH8-P Module	23
8 channel thermocouple and RTD amplifier	23
Module specifications	23
General	25
Push button	25
Connection	25
Programming information	26

Table of content

EPAD2/CPAD2-LA Module	27
Module specifications	27
Push button	29
Connection	29
Programming information	29
Installing CPAD2 modules	31
Installing CPAD2 modules in DEWESoft 7.x	31
Installing EPAD2 modules	34
Installing EPAD2 modules in DEWESoft 7.x	34
Module reset	36
EPAD2 Module reset:	36
CPAD2 Module reset:	36
Mounting examples	37
Mounting examples	37
Configuration examples	38
Configuration example with EPAD2 modules	38
Configuration example with CPAD2 modules	39
Accessories	40
Accessories & Options	40
CE-Certificate of conformity	C1

The information contained in this document is subject to change without notice.

DEWETRON elektronische Messgeraete Ges.m.b.H. (DEWETRON) shall not be liable for any errors contained in this document. DEWETRON MAKES NO WARRANTIES OF ANY KIND WITH REGARD TO THIS DOCUMENT, WHETHER EXPRESS OR IMPLIED. DEWETRON SPECIFICALLY DISCLAIMS THE IMPLIED WARRANTIES OF MERCHANTABILITY AND FITNESS FOR A PARTICULAR PURPOSE. DEWETRON shall not be liable for any direct, indirect, special, incidental, or consequential damages, whether based on contract, tort, or any other legal theory, in connection with the furnishing of this document or the use of the information in this document.

Warranty Information

A copy of the specific warranty terms applicable to your DEWETRON product and replacement parts can be obtained from your local sales and service office.

Support

For any support please contact your local distributor first or DEWETRON directly.

For Asia and Europe, please contact:

DEWETRON Ges.m.b.H.
Parkring 4
A-8074 Graz-Grambach
AUSTRIA
Tel.: +43 316 3070
Fax: +43 316 307090
Email: support@dewetron.com
Web: <http://www.dewetron.com>

The telephone hotline is available
Monday to Friday between
08:00 and 17:00 CET (GMT +1:00)

For the Americas, please contact:

DEWETRON, Inc.
10 High Street, Suite K
Wakefield, RI 02879
U.S.A.
Tel.: +1 401 284 3750
Toll-free: +1 877 431 5166
Fax: +1 401 284 3755
Email: support@dewamerica.com
Web: <http://www.dewamerica.com>

The telephone hotline is available
Monday to Friday between
08:00 and 17:00 GST (GMT -5:00)

Restricted Rights Legend

Use austrian law for duplication or disclosure.

DEWETRON GesmbH
Parkring 4
A-8074 Graz-Grambach / Austria

Printing History

Please refer to the page bottom for printing version.

Copyright © DEWETRON elektronische Messgeraete Ges.m.b.H.

This document contains information which is protected by copyright. All rights are reserved. Reproduction, adaptation, or translation without prior written permission is prohibited, except as allowed under the copyright laws.

All trademarks and registered trademarks are acknowledged to be the property of their owners.

Safety instructions

Safety symbols in the manual



Indicates hazardous voltages.

WARNING *Calls attention to a procedure, practice, or condition that could cause bodily injury or death.*

CAUTION *Calls attention to a procedure, practice, or condition that could possibly cause damage to equipment or permanent loss of data.*

WARNINGS

The following general safety precautions must be observed during all phases of operation, service, and repair of this product. Failure to comply with these precautions or with specific warnings elsewhere in this manual violates safety standards of design, manufacture, and intended use of the product. DEWETRON Elektronische Messgeraete Ges.m.b.H. assumes no liability for the customer's failure to comply with these requirements.

All accessories shown in this document are available as option and will not be shipped as standard parts.



*For safety reasons max. 50 V may be applied to the BNC input-connectors!
Refer to the regulation of maximum allowable touch potential.*

Safety instructions for all DEWETRON systems

- The DEWETRON data acquisition systems may only be installed by experts.
- Read your manual before operating the system.
- Observe local laws when using the instrument.
- Ground the equipment: For Safety Class 1 equipment (equipment having a protective earth terminal), a non interruptible safety earth ground must be provided from the mains power source to the product input wiring terminals or supplied power cable.
- DO NOT operate the product in an explosive atmosphere or in the presence of flammable gases or fumes and do not bring the system in contact with water.
- DO NOT operate damaged equipment: Whenever it is possible that the safety protection features built into this product have been impaired, either through physical damage, excessive moisture, or any other reason, REMOVE POWER and do not use the product until safe operation can be verified by service-trained personnel. If necessary, return the product to a DEWETRON sales and service office for service and repair to ensure that safety features are maintained.
- Keep away from live circuits: Operating personnel must not remove equipment covers or shields. Procedures involving the removal of covers or shields are for use by service-trained personnel only. Under certain conditions, dangerous voltages may exist even with the equipment switched off. To avoid dangerous electrical shock, DO NOT perform procedures involving cover or shield removal unless you are qualified to do so.
- No modifications are allowed at the instrument. The fuse in the power module has to be replaced by the same type. For continued protection against fire, replace the line fuse(s) only with fuse(s) of the same voltage and current rating and type. DO NOT use repaired fuses or short-circuited fuse holder labels and print on the power module may not be removed.
- DO NOT service or adjust alone. Do not attempt internal service or adjustment unless another person, capable of rendering first aid and resuscitation, is present.
- DO NOT substitute parts or modify equipment: Because of the danger of introducing additional hazards, do not install substitute parts or perform any unauthorized modification to the product. Return the product to a DEWETRON sales and service office for service and repair to ensure that safety features are maintained.
- Before opening the instrument (experts only) or exchanging the fuse in the power module disconnect power!
- Don't touch internal wiring!
- Don't use higher supply voltage than specified and take care of the correct polarity, otherwise the system will be damaged!
- Use only original plugs and cables for harnessing.
- Install filler-panels in unused slots.
- The power-cable and -connector serve as Power-Breaker. The cable must not exceed 10 feet, disconnect function must be possible without tools.
- Keep the ventilation slots free and check them frequently to avoid an overheating of the system. The cleaning interval of the filter pads depends on the environmental conditions.
- Safety of the operator and the unit depend on following these rules.
- DEWETRON is not responsible for any damage or injury that could result from improper connection or misuse!

General Information

Environmental Considerations

Information about the environmental impact of the product.

Product End-of-Life Handling

Observe the following guidelines when recycling a DEWETRON system:

System and Components Recycling

Production of these components required the extraction and use of natural resources. The substances contained in the system could be harmful to your health and to the environment if the system is improperly handled at its end of life! Please recycle this product in an appropriate way to avoid an unnecessary pollution of the environment and to keep natural resources.

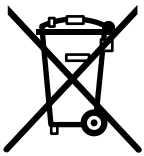

This symbol indicates that this system complies with the European Union's requirements according to Directive 2002/96/EC on waste electrical and electronic equipment (WEEE). Please find further informations about recycling on the DEWETRON web site www.dewetron.com

Restriction of Hazardous Substances

This product has been classified as Monitoring and Control equipment, and is outside the scope of the 2002/95/EC RoHS Directive. This product is known to contain lead.

General module information

Calibration information

All DEWETRON modules are calibrated at 25 °C and meet their specifications when leaving the factory. The time interval for recalibration depends on environmental conditions. Typically, the calibration should be checked once a year.

Calibration certificates are available from DEWETRON as an option. DEWETRON offers two types:

- ISO traceable DEWETRON certificate
- Calibration certificate according to ÖKD (equivalent to DKD)

This manual contains no calibration information. For self calibration, there is a separate calibration kit available. The CAL-KIT contains the required cables, software and instructions.

General module specifications

Environmental:

Temp. range storage:	-30 °C to +85 °C	(-30 °F to 185 °F)
Temp. range operating:	-5 °C to +60 °C	(-4 °F to 140 °F)
Enhanced temp. range:	on request	
Relative humidity (MIL202):	0 to 95 % at 60 °C, non-condensing	
RFI susceptibility:	±0.5 % span error at 400 MHz, 5 W, 3 m	

All modules are produced according ISO9001 and ISO14001.

Notes

EPAD2/CPAD2-TH8-x Module

8 channel thermocouple amplifier

- Intelligent amplifier with integrated A/D conversion
- 8 input channels for thermocouples
- Available thermocouple types:
 - xPAD-TH8-P-K: K type
 - xPAD-TH8-P-J: J type
 - xPAD-TH8-P-T: T type
- RS-485 or CAN interface



Module specifications

xPAD2-TH8-x	
Input channels:	8 isolated Thermocouple Channels
Input signals:	thermocouple types depending on module
xPAD2-TH8-J:	J: -210 °C to 1200 °C
xPAD2-TH8-K:	K: -270 °C to 1372 °C
xPAD2-TH8-T:	T: -270 °C to 400 °C
	other types on request
Sampling rate:	max. 12.5 S/sec per channel
Bandwidth (-3 dB):	6 Hz
ADC Type:	24 Bit Delta Sigma Converter
Input connector:	mini Thermocouple connector
Resolution:	0.01 °C for all types
Input Impedance	typically 1.4 MΩ
Bias Current:	typically 10 nA
Open Thermocouple detection:	module indicates fullscale if input is open
Accuracy:	
Thermocouple type J:	±1.0 °C @ -210 to -100 °C ±0.3 °C @ -100 to 760 °C ±0.4 °C @ 760 to 1200 °C
Thermocouple type K:	±1.0 °C @ -200 to -25 °C ±0.4 °C @ -25 to 1000 °C ±0.5 °C @ 1000 to 1372 °C
Thermocouple type T:	±1.0 °C @ -250 to -150 °C ±0.4 °C @ -150 to 400 °C
Temperature drift:	typically 20 ppm/°C
Isolation voltage:	350 V _{DC} (channel to channel and channel to Bus, Power and Chassis)
Overvoltage protection:	15 V _{DC}
CMRR (50/60 Hz):	130 dB
EPAD2-TH8	
Interface:	RS-485
Communication speed:	9600 bps (2400 to 115200 programmable)
Standard settings:	9600 bps, 8 data bits, 1 stop bit, no parity, module address 00 hex
Readout speed:	depending on baudrate and number of channels (typ. 80 ch/sec. @ 9600bps)
CPAD2-TH8	
Interface:	highspeed CAN
Specification	CAN 2.0B
Communication speed:	50 kBaud to 1000 kBaud
Data Format	16 Bit Intel or Motorola
Identifier Types	standard; extended
Standard settings:	500 kBaud; Intel Format
Readout speed:	12.5Hz, 10Hz, 5Hz, 2Hz, 1Hz, 0.5Hz, 0.2Hz or 0.1Hz programmable
Bus/Power Connector:	LEMO EGG.1B.304
Power Supply Voltage:	7 to 40V
Power consumption:	max 0.5 W
Dimensions:	
Base module (W x D x H):	129 x 72 x 34.2 mm (5.1 x 2.8 x 1.3 in.) incl. mounting holes
Mounting holes distance:	119 x 7 mm (4.7 x 0.3 in.), 4.2 mm (0.165 in.) diameter
Weight:	typically 360 g

EPAD2/CPAD2-TH8-x Module

Dimensions*

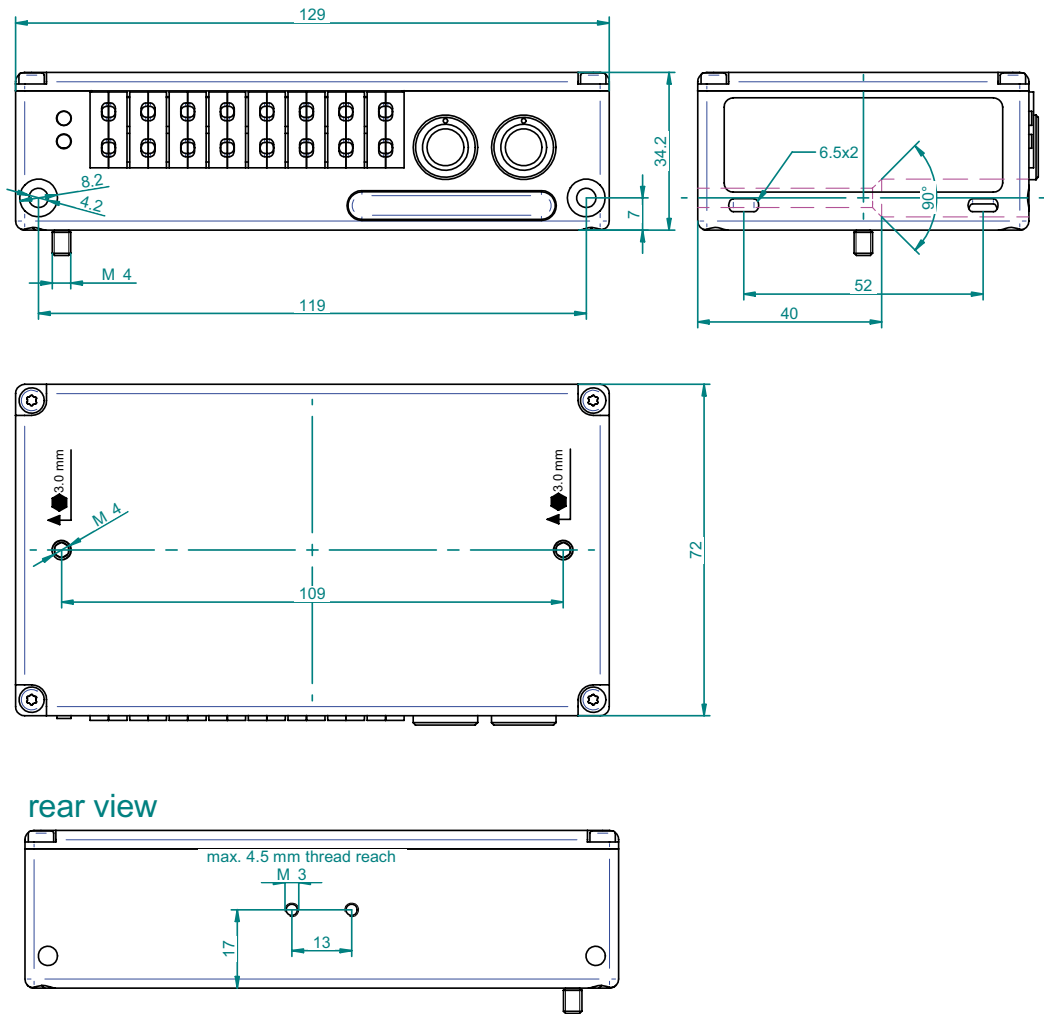

* Dimensions in mm
(1 inch = 25.4 mm)

EPAD2/CPAD2-TH8-x Module

Push button

Use the ID button to define the module address via software. Detailed information how to use the button is available in chapter: "Installing EPAD2/CPAD2 modules in DEWESoft, Module reset".

Connection

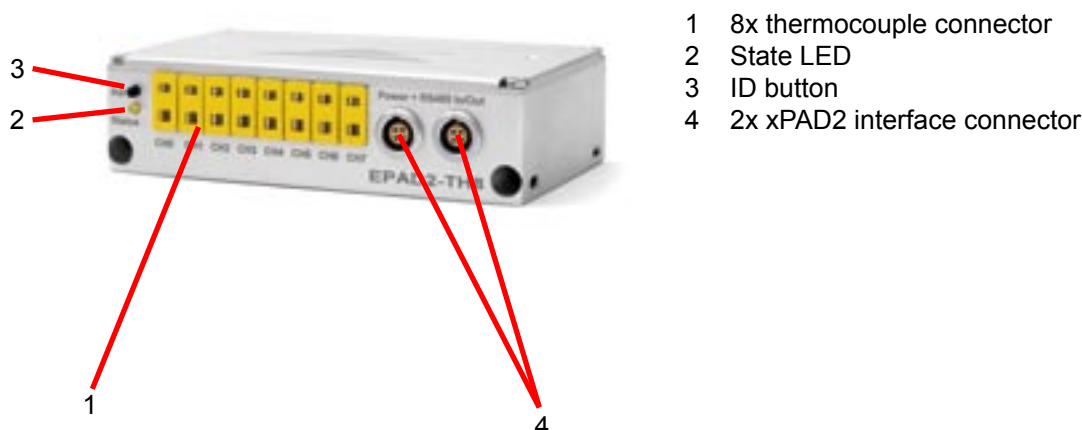

Thermocouple connectors

The xPAD2-TH8-x module supports up to 8 thermocouples. Connect only thermocouple types which match with the connector types. If the module is equipped with type K connectors, you are allowed to connect type K thermocouples only.



Type	Color	+	-
Type K	yellow	NiCr	NiAl
Type J	black	Fe	CuNi
Type T	blue	Cu	CuNi

xPAD2 interface connector

This connector can be used to connect the module to the EPAD2-BASE module or other xPAD2 series modules.

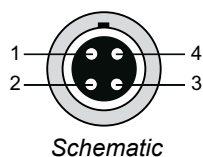

Pin assignment EPAD2:

- 1 RS-485 (A)
- 2 RS-485 (B)
- 3 Power supply (+)
(standard: +15 V)
- 4 GND

Pin assignment CPAD2:

- 1 CAN high
- 2 CAN low
- 3 Power supply (+)
(standard: +15 V)
- 4 GND

Programming information

The xPAD2-TH8-x programming information is available in the *DEWE-MODULES Programmers Reference Manual*.

EPAD2/CPAD2-TH8-x Module

Notes

EPAD2/CPAD2-V8 Module

8 channel voltage amplifier

- Intelligent amplifier with integrated 24-bit A/D conversion
- 8 channel isolated data acquisition
- RS-485 or CAN interface



Module specifications

xPAD2-V8	
Input channels:	8 isolated voltage input channels
Input Ranges:	Physical input range: ± 50 V Software selectable: ± 100 mV, ± 500 mV, ± 1 V, ± 2.5 V, ± 5 V, ± 10 V
Resolution:	10 μ V for all ranges
DC accuracy:	± 0.02 % of reading ± 900 μ V
Temperature Drift:	typically 25 ppm/ $^{\circ}$ C
Linearity:	0.001 %
Input impedance	1 M Ω
Input connector	SUB-D 25
Sampling rate:	max. 12.5 S/sec per channel
Bandwidth (-3 dB):	6 Hz
ADC Type	24 Bit Delta Sigma Converter
Isolation voltage:	350 V _{DC} (channel to channel and channel to Bus, Power and Chassis)
Overvoltage protection:	350 V _{DC}
Common mode voltage:	350 V _{DC} / 250 V _{AC} @ 50 Hz
CMRR (50/60 Hz):	110 dB (140 dB @ DC)
EPAD2-V8	
Interface:	RS-485
Communication speed:	9600 bps (2400 to 115200 programmable)
Standard settings:	9600 bps, 8 data bits, 1 stop bit, no parity, module address 00 hex
Readout speed:	depending on baudrate and number of channels (typ. 80 ch/sec. @ 9600 bps)
CPAD2-V8	
Interface:	highspeed CAN
Specification:	CAN 2.0B
Communication speed:	50 kBaud to 1000 kBaud
Data Format	16 Bit Intel or Motorola
Identifier Types	standard; extended
Standard settings:	500 kBaud; Intel Format
Readout speed:	12.5 Hz, 10 Hz, 5 Hz, 2 Hz, 1 Hz, 0.5 Hz, 0.2 Hz or 0.1 Hz programmable
Bus/Power Connector	LEMO EGG.1B.304
Power Supply Voltage:	7 to 40V
Power consumption:	max. 0.5 W
Dimensions:	
Base module (W x D x H):	129 x 72 x 34.2 mm (5.1 x 2.8 x 1.3 in.) incl. mounting holes
Mounting holes distance:	119 x 7 mm (4.7 x 0.3 in.), 4.2 mm (0.165 in.) diameter
Weight:	typically 310 g

EPAD2/CPAD2-V8 Module

Dimensions*

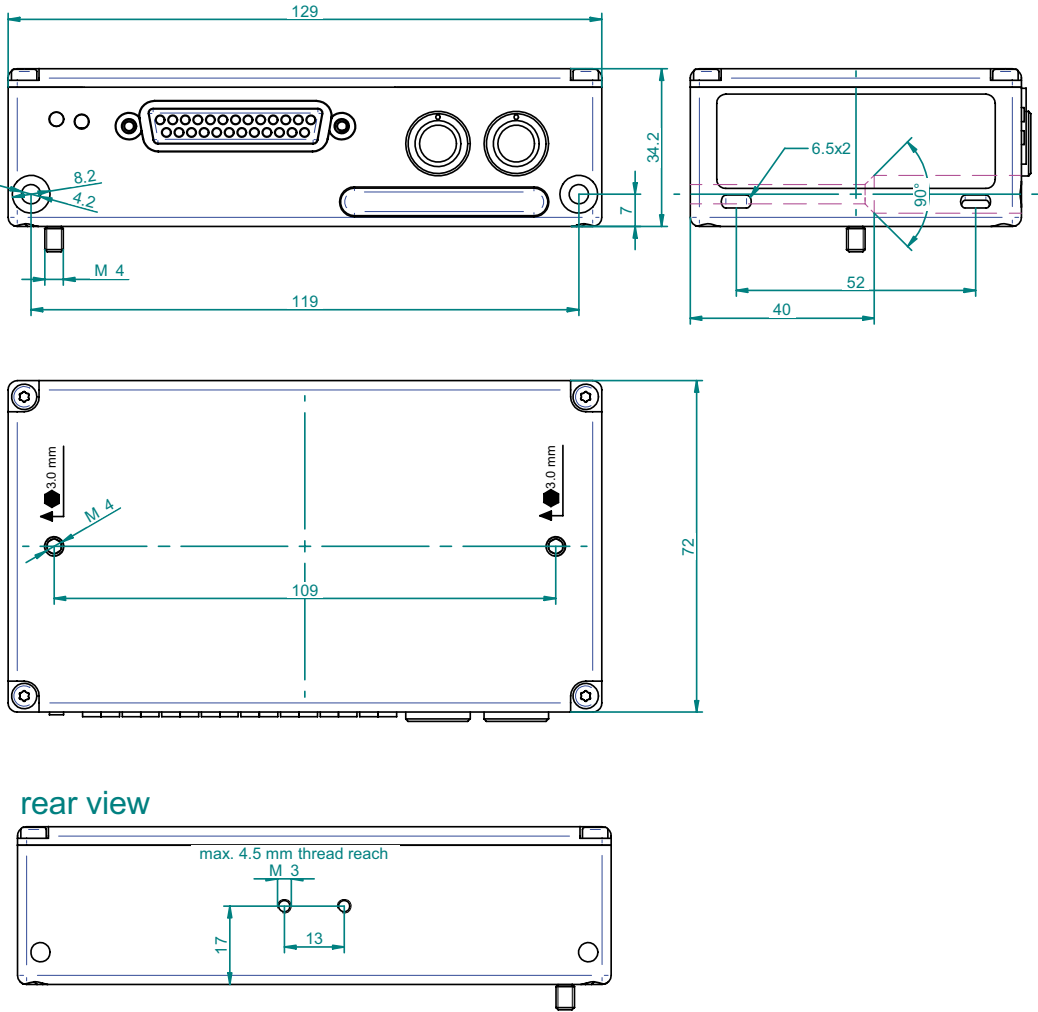

* Dimensions in mm
(1 inch = 25.4 mm)

EPAD2/CPAD2-V8 Module

Push button

Use the ID button to define the module address via software. Detailed information how to use the button is available in chapter: "Installing EPAD2/CPAD2 modules in DEWESoft, Module reset".

Connection



- 1 Voltage input connector
- 2 State LED
- 3 ID button
- 4 2x xPAD2 interface connector

Voltage input connector

The xPAD2-V8 module offers 8 differential voltage input channels.



25-pin female DSUB connector

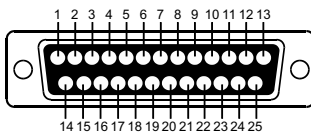

Schematic

Pin assignment:

1	Channel 0	(+)	13	Channel 6	(+)
2	Channel 0	(-)	14	Channel 6	(-)
3	Channel 1	(+)	15	Channel 7	(+)
4	Channel 1	(-)	16	Channel 7	(-)
5	Channel 2	(+)	17	Reserved	
6	Channel 2	(-)	18	Reserved	
7	Channel 3	(+)	19	Reserved	
8	Channel 3	(-)	20	Power supply (+)	
9	Channel 4	(+)	21	Reserved	
10	Channel 4	(-)	22	GND	
11	Channel 5	(+)	23	Reserved	
12	Channel 5	(-)	24	Reserved	
			25	Reserved	

xPAD2 interface connector

This connector can be used to connect the module to the EPAD-BASE2 module or other xPAD2 series



4 pin LEMO series connector

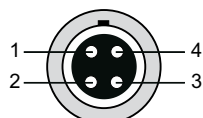

Schematic

Pin assignment EPAD2:

- 1 RS-485 (A)
- 2 RS-485 (B)
- 3 Power supply (+)
(standard: +15 V)
- 4 GND

Pin assignment CPAD2:

- 1 CAN high
- 2 CAN low
- 3 Power supply (+)
(standard: +15 V)
- 4 GND

EPAD2/CPAD2-V8 Module

Programming information

The xPAD-V8 programming information is available in the *DEWE-MODULES Programmers Reference Manual*.

EPAD2/CPAD2-RTD8 Module

8 channel Resistance Temperature Detector amplifier

- Amplifier with integrated 24-bit A/D conversion
- 8 isolated Resistance Temperature Detector channels
- RS-485 or CAN interface



Module specifications

xPAD2-RTD8																									
Input channels:	8 isolated Resistance Temperature Detector channels																								
Input Ranges:	Resistor: 0 to 999.99Ohm RTD: PT100(385); PT200(385); PT500(385); PT1000(385); PT2000(385); PT100(3961)																								
Accuracy:	<table border="0"> <tr> <td>Pt100 a = 0.00385</td> <td>Pt100 a = 0.003916</td> <td>Pt200 a = 0.00385</td> </tr> <tr> <td>±0.25 °C @ -200 to 100 °C</td> <td>±0.25 °C @ -200 to 100 °C</td> <td>±0.25 °C @ -200 to 100 °C</td> </tr> <tr> <td>±0.4 °C @ 100 to 400 °C</td> <td>±0.4 °C @ 100 to 400 °C</td> <td>±0.4 °C @ 100 to 400 °C</td> </tr> <tr> <td>±0.8 °C @ 400 to 800 °C</td> <td>±0.8 °C @ 400 to 800 °C</td> <td>±0.5 °C @ 400 to 630 °C</td> </tr> <tr> <td>Pt500 a = 0.00385</td> <td>Pt1000 a = 0.00385</td> <td>Pt2000 a = 0.00385</td> </tr> <tr> <td>±0.25 °C @ -200 to 100 °C</td> <td>±0.25 °C @ -200 to 100 °C</td> <td>±0.25 °C @ -200 to 100 °C</td> </tr> <tr> <td>±0.4 °C @ 100 to 250 °C</td> <td>±0.4 °C @ 100 to 400 °C</td> <td>±0.4 °C @ 100 to 400 °C</td> </tr> <tr> <td></td> <td>±0.8 °C @ 400 to 600 °C</td> <td>±0.8 °C @ 400 to 600 °C</td> </tr> </table>	Pt100 a = 0.00385	Pt100 a = 0.003916	Pt200 a = 0.00385	±0.25 °C @ -200 to 100 °C	±0.25 °C @ -200 to 100 °C	±0.25 °C @ -200 to 100 °C	±0.4 °C @ 100 to 400 °C	±0.4 °C @ 100 to 400 °C	±0.4 °C @ 100 to 400 °C	±0.8 °C @ 400 to 800 °C	±0.8 °C @ 400 to 800 °C	±0.5 °C @ 400 to 630 °C	Pt500 a = 0.00385	Pt1000 a = 0.00385	Pt2000 a = 0.00385	±0.25 °C @ -200 to 100 °C	±0.25 °C @ -200 to 100 °C	±0.25 °C @ -200 to 100 °C	±0.4 °C @ 100 to 250 °C	±0.4 °C @ 100 to 400 °C	±0.4 °C @ 100 to 400 °C		±0.8 °C @ 400 to 600 °C	±0.8 °C @ 400 to 600 °C
Pt100 a = 0.00385	Pt100 a = 0.003916	Pt200 a = 0.00385																							
±0.25 °C @ -200 to 100 °C	±0.25 °C @ -200 to 100 °C	±0.25 °C @ -200 to 100 °C																							
±0.4 °C @ 100 to 400 °C	±0.4 °C @ 100 to 400 °C	±0.4 °C @ 100 to 400 °C																							
±0.8 °C @ 400 to 800 °C	±0.8 °C @ 400 to 800 °C	±0.5 °C @ 400 to 630 °C																							
Pt500 a = 0.00385	Pt1000 a = 0.00385	Pt2000 a = 0.00385																							
±0.25 °C @ -200 to 100 °C	±0.25 °C @ -200 to 100 °C	±0.25 °C @ -200 to 100 °C																							
±0.4 °C @ 100 to 250 °C	±0.4 °C @ 100 to 400 °C	±0.4 °C @ 100 to 400 °C																							
	±0.8 °C @ 400 to 600 °C	±0.8 °C @ 400 to 600 °C																							
Sampling rate:	max. 12.5 S/sec per channel																								
Bandwidth (-3 dB):	6 Hz																								
ADC Type:	24 Bit Delta Sigma Converter																								
Input Connector:	ERA.1S.304																								
Connection Type:	2-wire, 4wire																								
Noise:	typically 0.01 °C																								
Resolution:	0.01 °C for all types																								
Consdand Current:	190 µA																								
Input Impedance:	typically >100 MΩ																								
Bias Current:	typically 10 nA																								
Sensor fault detection:	module indicates fullscale if input is open																								
Temperature drift:	typically 15 ppm/°C																								
Isolation voltage:	350 V _{DC} (channel to channel and channel to Bus, Power and Chassis)																								
Overvoltage protection:	15 V _{DC}																								
CMRR (50/60 Hz):	130 dB																								
EPAD2-RTD8																									
Interface:	RS-485																								
Communication speed:	9600 bps (2400 to 115200 programmable)																								
Standard settings:	9600 bps, 8 data bits, 1 stop bit, no parity, module address 00 hex																								
Readout speed:	depending on baudrate and number of channels (typ. 80 ch/sec. @ 9600 bps)																								
CPAD2-RTD8																									
Interface:	highspeed CAN																								
Specification:	CAN 2.0B																								
Communication speed:	50 kBaud to 1000 kBaud																								
Data Format:	16 Bit Intel or Motorola																								
Identifier Types:	standard; extended																								
Standard settings:	500 kBaud; Intel Format																								
Readout speed:	12.5 Hz, 10 Hz, 5 Hz, 2 Hz, 1 Hz, 0.5 Hz, 0.2 Hz or 0.1 Hz programmable																								
Bus/Power Connector:	LEMO EGG.1B.304																								
Power Supply Voltage:	7 to 40 V																								
Power consumption:	typically 0.5 W																								
Dimensions:																									
Base module (W x D x H):	129 x 72 x 34.2 mm (5.1 x 2.8 x 1.3 in.) incl. mounting holes																								
Mounting holes distance:	119 x 7 mm (4.7 x 0.3 in.), 4.2 mm (0.165 in.) diameter																								
Weight:	typical 420 g																								

EPAD2/CPAD2-RTD8 Module

Dimensions*

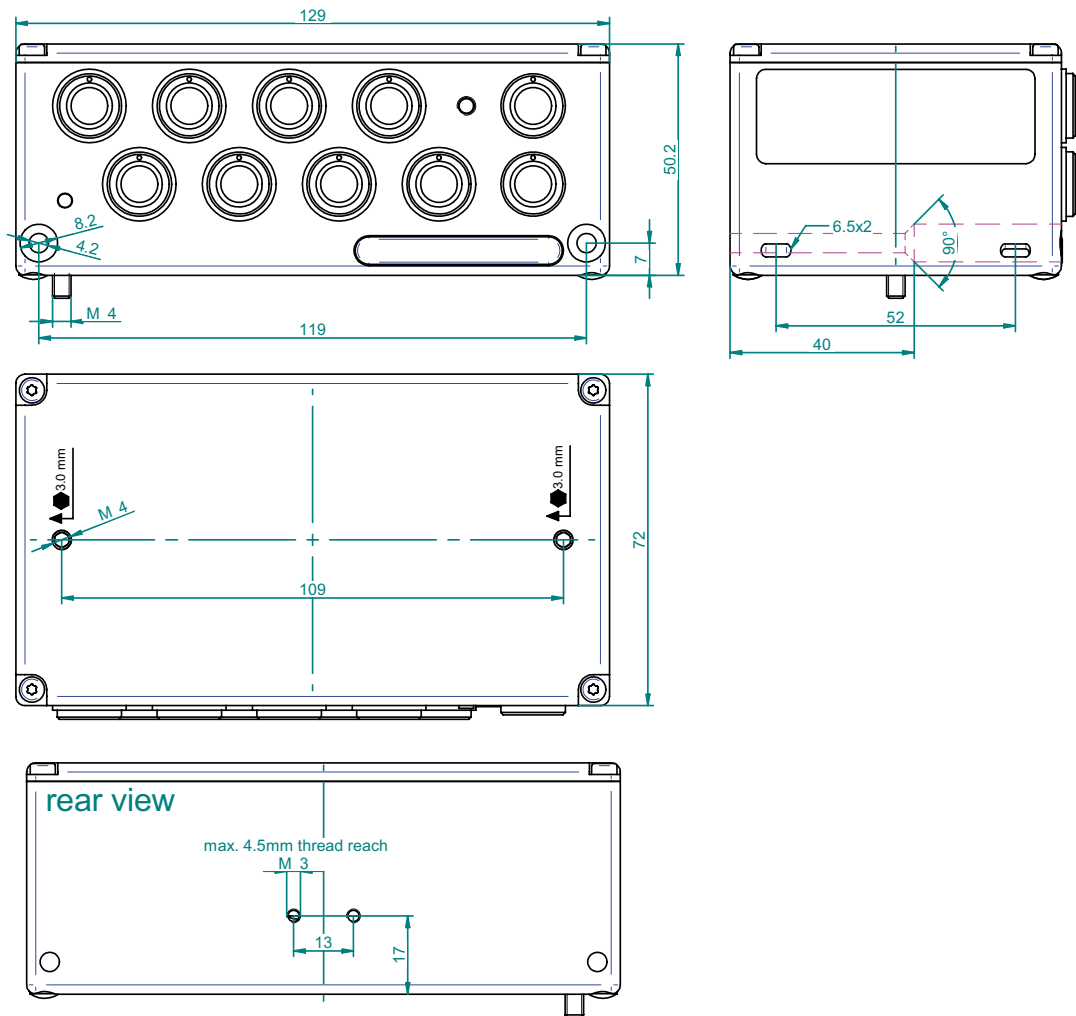

* Dimensions in mm
(1 inch = 25.4 mm)

EPAD2/CPAD2-RTD8 Module

Push button

Use the ID button to define the module address via software. Detailed information how to use the button is available in chapter: "Installing EPAD2/CPAD2 modules in DEWESoft, Module reset".

Connection

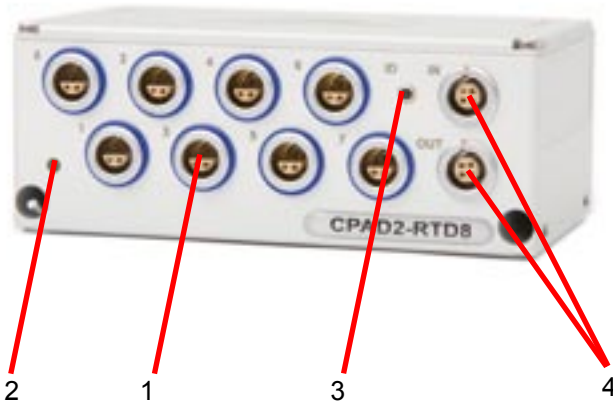

- 1 RTD input connectors
- 2 State LED
- 3 ID button
- 4 2x xPAD2 interface connector

RTD input connector

The xPAD2-RTD8 module offers 8 isolated Resistor Temperature Detector input channels.



ERA.1S.304.CLL



Schematic

Pin assignment:

- 1 Excitation (+)
 - 2 Sense (+)
 - 3 Sense (-)
 - 4 Excitation (-)
- Shield is on housing

xPAD2 interface connector

This connector can be used to connect the module to the EPAD-BASE2 module or other xPAD2 series



4 pin LEMO series connector

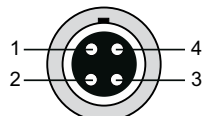

Schematic

Pin assignment EPAD2:

- 1 RS-485 (A)
- 2 RS-485 (B)
- 3 Power supply (+)
(standard: +15 V)
- 4 GND

Pin assignment CPAD2:

- 1 CAN high
- 2 CAN low
- 3 Power supply (+)
(standard: +15 V)
- 4 GND

EPAD2/CPAD2-RTD8 Module

Sensor connection

2-wire connection

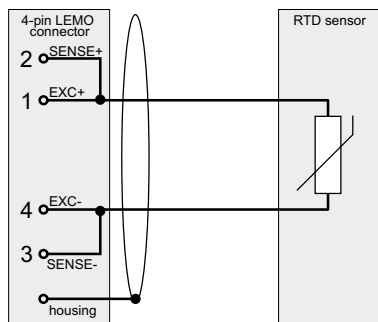

4-wire connection

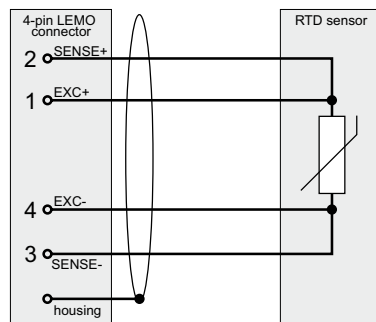

Programming information

The xPAD-RTD8 programming information is available in the *DEWE-MODULES Programmers Reference Manual*.

EPAD2/CPAD2-TH8-P Module

8 channel thermocouple and RTD amplifier

- Intelligent amplifier with integrated 24-bit A/D conversion
- 8 galvanically isolated input channels
- External CJC
- Automatic sensor block detection
- Signal connection via 25-pin SUB-D connector
- Supported breakout boxes:
 - PAD-CB8-x-P2: standard thermocouple breakout box
 - PAD-CB8-x-M: small size thermocouple breakout box
 - PAD-CB8-RTD: RTD breakout box



Module specifications

xPAD2-TH8-P	
Input channels:	8 isolated voltage inputs
Input Range	±1.5 V
Sampling rate:	max. 12.5 S/sec per channel
Bandwidth (-3 dB):	6 Hz
ADC Type:	24 Bit Delta Sigma Converter
Input connector:	SUB-D 25
Resolution:	1 µV
Input Impedance:	typically 1.4 MΩ
Bias Current:	typically 10 nA
Temperature drift:	typically 20 ppm/°C
Isolation voltage:	350 V _{DC} (channel to channel and channel to bus, power and chassis)
Overvoltage protection:	15 V _{DC}
CMRR (50/60 Hz):	130 dB
Supported Breakout Boxes:	PAD-CB8-x-P2 standard thermocouple breakout box PAD-CB8-x-M small size thermocouple breakout box PAD-CB8-RTD RTD breakout box
EPAD2-TH8-P	
Interface:	RS-485
Communication speed:	9600 bps (2400 to 115200 programmable)
Standard settings:	9600 bps, 8 data bits, 1 stop bit, no parity, module address 00 hex
Readout speed:	depending on baudrate and number of channels (typ. 80 ch/sec. @ 9600 bps)
CPAD2-TH8-P	
Interface:	highspeed CAN
Specification:	CAN 2.0B
Communication speed:	50 kBaud to 1000 kBaud
Data Format :	16 Bit Intel or Motorola
Identifier Types:	standard; extended
Standard settings:	500 kBaud; Intel Format
Readout speed:	12.5 Hz, 10 Hz, 5 Hz, 2 Hz, 1 Hz, 0.5 Hz, 0.2 Hz or 0.1 Hz programmable
Bus/Power Connector:	LEMO EGG.1B.304
Power Supply Voltage:	7 to 40 V
Power consumption:	max. 0.5 W
Dimensions:	
Base module (W x D x H):	129 x 72 x 34.2 mm (5.1 x 2.8 x 1.3 in.) incl. mounting holes
Mounting holes distance:	119 x 7 mm (4.7 x 0.3 in.), 4.2 mm (0.165 in.) diameter
Weight:	typical 310 g

EPAD2/CPAD2-TH8-P Module

Dimensions*

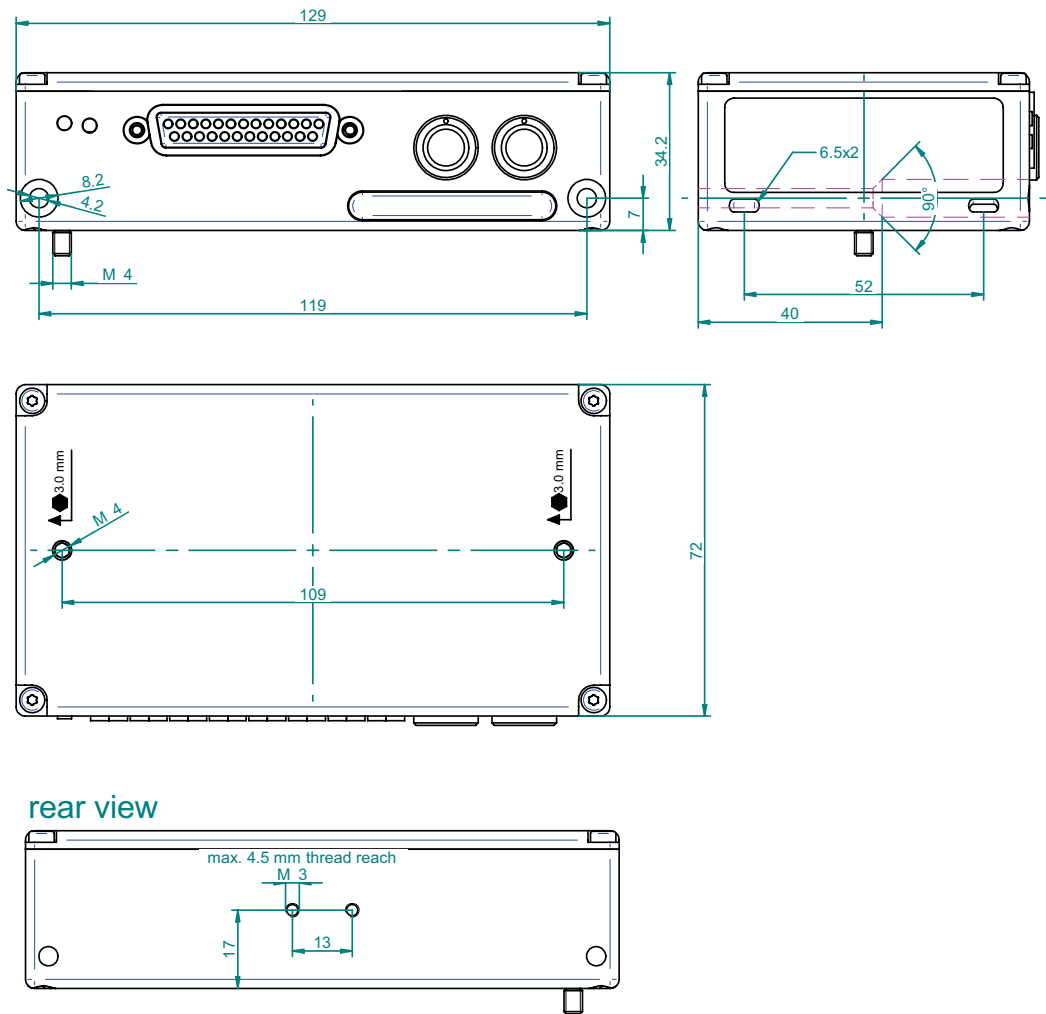

* Dimensions in mm
(1 inch = 25.4 mm)

EPAD2/CPAD2-TH8-P Module

General

To use the full power of the xPAD2-TH8-P module, a supported breakout box for RTD and thermocouple sensors should be ordered together with the module.

Supported breakout boxes: PAD-CB8-x-P2 standard thermocouple breakout box
 PAD-CB8-x-M small size thermocouple box
 PAD-CB8-RTD RTD breakout box

Push button

Use the ID button to define the module address via software. Detailed information how to use the button is available in chapter: "Installing EPAD2/CPAD2 modules in DEWESoft, Module reset".

Connection



- 1 Voltage input connector
- 2 State LED
- 3 ID button
- 4 2x xPAD2 interface connector

Voltage input connector

The xPAD2-TH8-P module offers 8 differential voltage input channels.

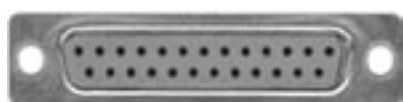

25-pin female DSUB connector

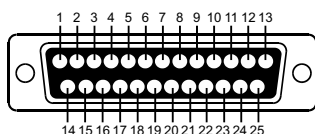

Schematic

Pin assignment:

1	Channel 0	(+)	13	Channel 6	(+)
2	Channel 0	(-)	14	Channel 6	(-)
3	Channel 1	(+)	15	Channel 7	(+)
4	Channel 1	(-)	16	Channel 7	(-)
5	Channel 2	(+)	17	Reserved	
6	Channel 2	(-)	18	Reserved	
7	Channel 3	(+)	19	Reserved	
8	Channel 3	(-)	20	Power supply (+)	
9	Channel 4	(+)	21	Reserved	
10	Channel 4	(-)	22	GND	
11	Channel 5	(+)	23	Reserved	
12	Channel 5	(-)	24	Reserved	
			25	Reserved	

EPAD2/CPAD2-TH8-P Module

xPAD2 interface connector

This connector can be used to connect the module to the EPAD-BASE2 module or other xPAD2 series



4 pin LEMO series
connector

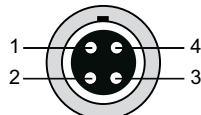

Schematic

Pin assignment EPAD2:

- 1 RS-485 (A)
- 2 RS-485 (B)
- 3 Power supply (+)
(standard: +15 V)
- 4 GND

Pin assignment CPAD2:

- 1 CAN high
- 2 CAN low
- 3 Power supply (+)
(standard: +15 V)
- 4 GND

Programming information

The xPAD2-TH8-P-x programming information is available in the *DEWE-MODULES Programmers Reference Manual*.

EPAD2/CPAD2-LA Module

8 channel high precision amplifier for 4 to 20 mA sensors

- Intelligent amplifier with integrated 24-bit A/D conversion
- 8 galvanically isolated input channels
- RS-485 or CAN interface



Module specifications

xPAD2-LA	
Input channels:	8 isolated Current Inputs
Input range:	0 to 20 mA, ± 20 mA; ± 30 mA
Accuracy	0.03 % of reading ± 0.3 μ A
Sampling rate:	max. 12.5 S/sec per channel
Bandwidth (-3 dB):	6 Hz
ADC Type:	24 Bit Delta Sigma Converter
Input connector:	LEMO EGB.1B.304
Resolution:	0.3 μ A
Input Impedance	50 Ω 0.1 %
Temperature drift:	typically 20 ppm/ $^{\circ}$ C
Isolation voltage:	350 V _{DC} (channel to channel and channel to Bus, Power and Chassis)
Overcurrent protection:	70 mA continuous
CMRR (50/60 Hz):	130 dB
EPAD2-TH8-P	
Interface:	RS-485
Communication speed:	9600 bps (2400 to 115200 programmable)
Standard settings:	9600 bps, 8 data bits, 1 stop bit, no parity, module address 00 hex
Readout speed:	depending on baudrate and number of channels (typ. 80 ch/sec. @ 9600 bps)
CPAD2-TH8-P	
Interface:	highspeed CAN
Specification:	CAN 2.0B
Communication speed:	50 kBaud to 1000 kBaud
Data Format :	16 Bit Intel or Motorola
Identifier Types:	standard; extended
Standard settings:	500 kBaud; Intel Format
Readout speed:	12.5 Hz, 10 Hz, 5 Hz, 2 Hz, 1 Hz, 0.5 Hz, 0.2 Hz or 0.1 Hz programmable
Bus/Power Connector:	LEMO EGG.1B.304
Power Supply Voltage:	7 to 40 V
Power consumption:	max. 0.5 W
Dimensions:	
Base module (W x D x H):	129 x 72 x 34.2 mm (5.1 x 2.8 x 1.3 in.) incl. mounting holes
Mounting holes distance:	119 x 7 mm (4.7 x 0.3 in.), 4.2 mm (0.165 in.) diameter
Weight:	typical 360 g

EPAD2/CPAD2-LA Module

Dimensions*

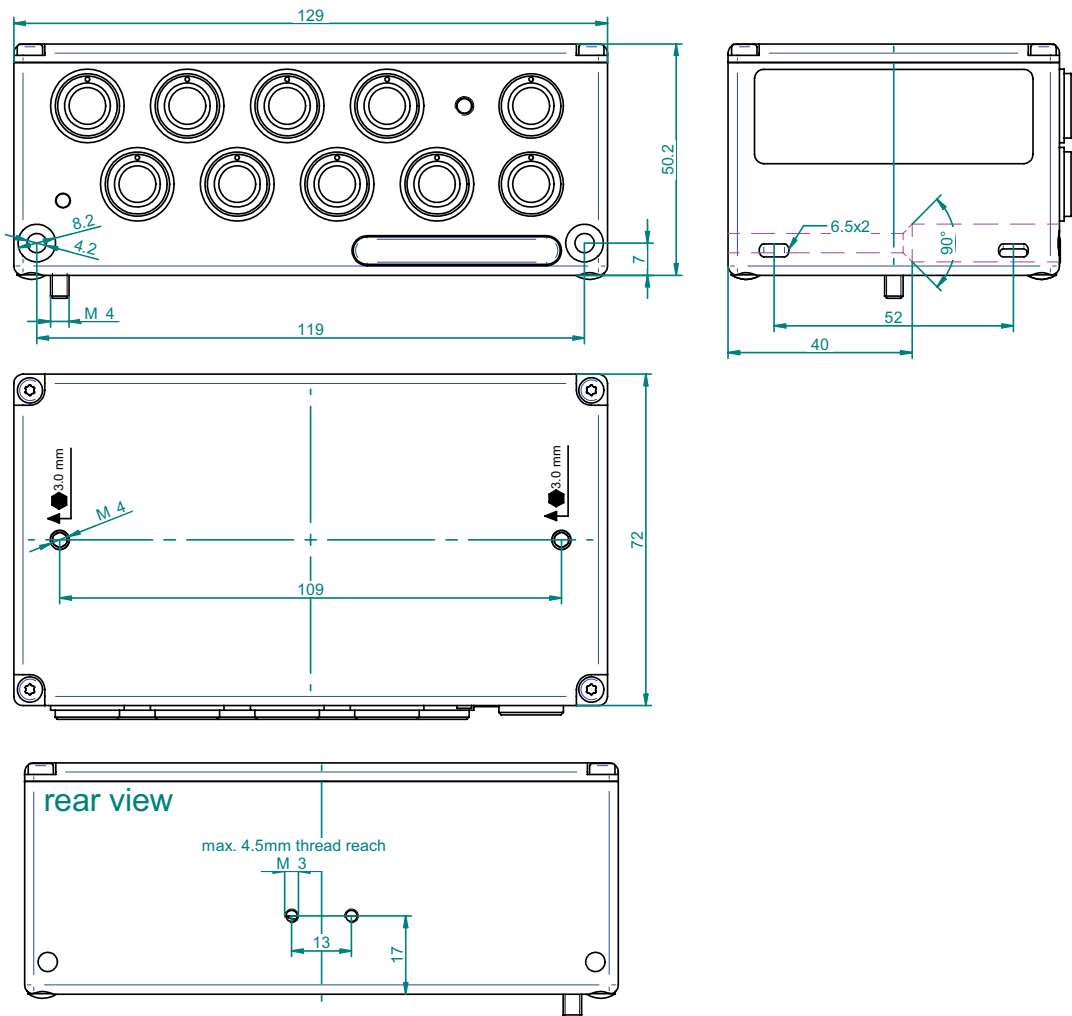

* Dimensions in mm
(1 inch = 25.4 mm)

EPAD2/CPAD2-LA Module

Push button

Use the ID button to define the module address via software. Detailed information how to use the button is available in chapter: "Installing EPAD2/CPAD2 modules in DEWESoft, Module reset".

Connection

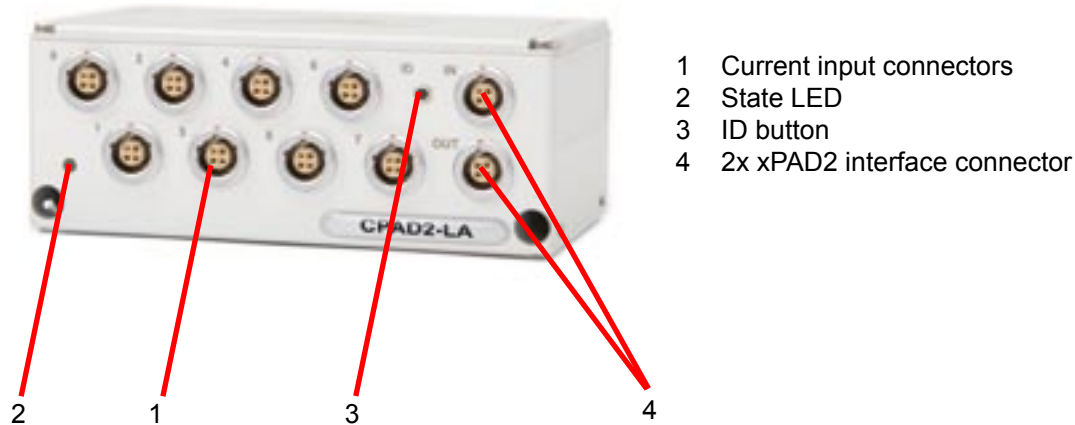

LA input connector

The xPAD2-LA module offers 8 isolated current input channels.



EGB.1B.304

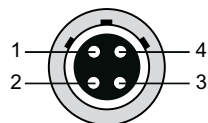

Schematic

Pin assignment:

- 1 Power supply (+)
 - 2 Current (+)
 - 3 Current (-)
 - 4 Power supply (-)
- Shield is on housing

xPAD2 interface connector

This connector can be used to connect the module to the EPAD-BASE2 module or other xPAD2 series



4 pin LEMO series connector

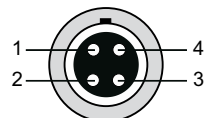

Schematic

Pin assignment EPAD2:

- 1 RS-485 (A)
- 2 RS-485 (B)
- 3 Power supply (+)
(standard: +15 V)
- 4 GND

Pin assignment CPAD2:

- 1 CAN high
- 2 CAN low
- 3 Power supply (+)
(standard: +15 V)
- 4 GND

Programming information

The xPAD2-RTD8 programming information is available in the *DEWE-MODULES Programmers Reference Manual*.

EPAD2/CPAD2-LA Module

Notes

Installing CPAD2 modules

Installing CPAD2 modules in DEWESoft 7.x

Activate CPAD2 modules

Click on "Settings" > "Hardware Setup" > "CAN"

- Select the CAN device you are using
- Set the CAN Port you use for the CPAD to acknowledge
- Set the CAN Port to CPAD2 in the special devices section.

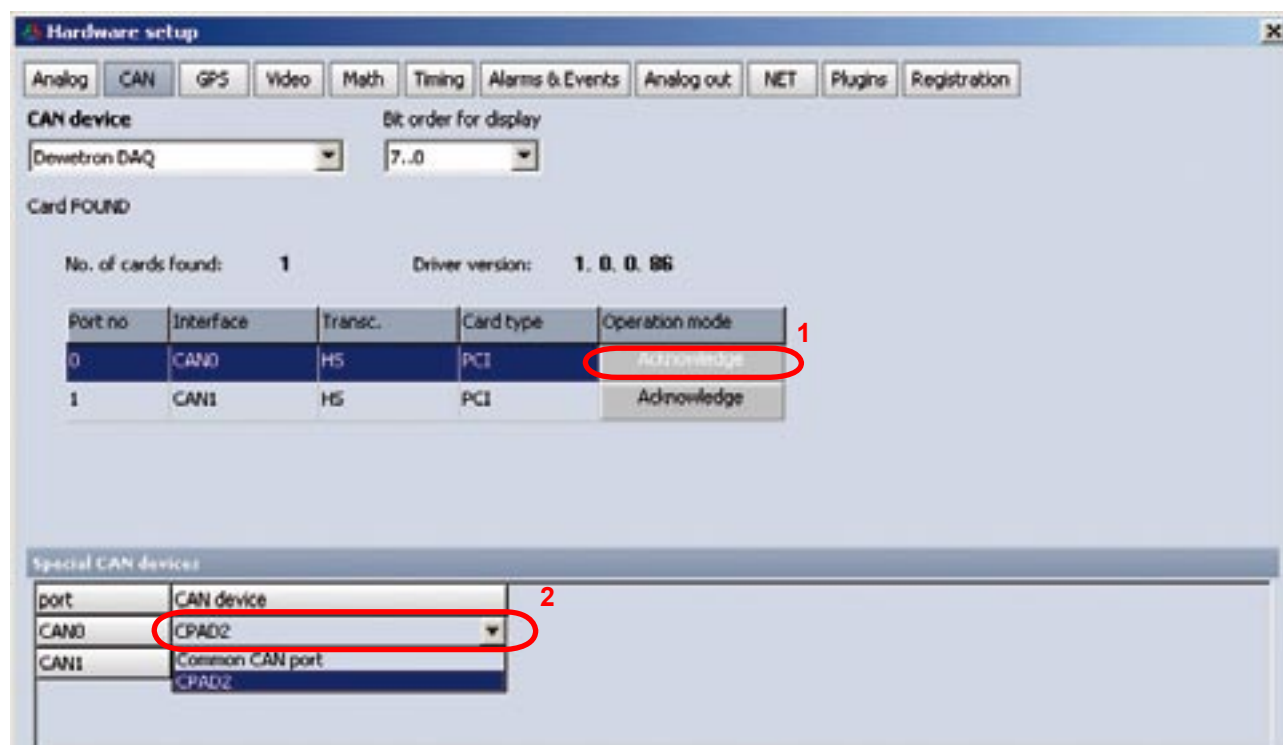

Figure 1: Activate CPAD2 modules

Configuring CPAD2 modules

Click on "CH. Setup" > "CAN" > "CANx" > "Config"

Here it is possible to configure your can modules. Automatically all connected CPAD modules should be found in one of the two sections. You can move modules with "drag and drop" from the used to the unused section.

The status LED of the modules will help you to configure the modules:

- LED is on: Module is in the used section
- LED is off: Module is in the unused section
- LED is blinking: Module is selected with the mouse.

Installing CPAD2 modules

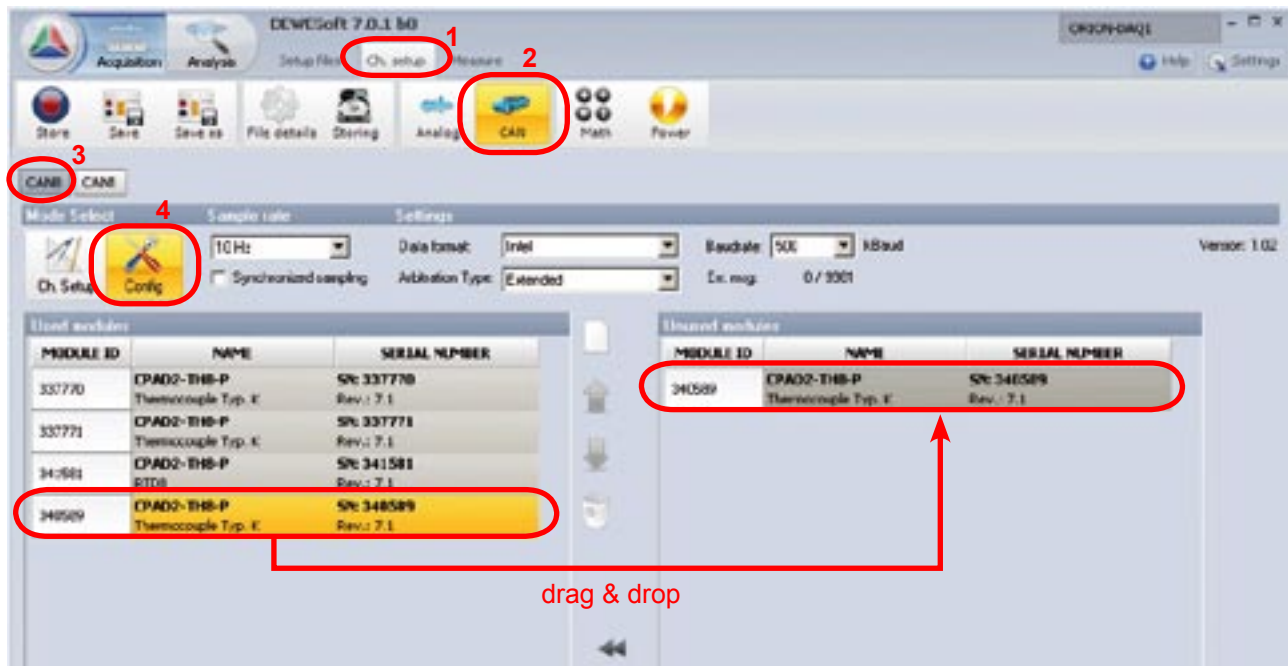

Figure 2: configuring CPAD2 modules

Unused modules do not send any data. The sample rate is 0.

All modules listed in the "used modules" are automatically sorted by the module ID.

By default the module ID is the serial number, but it could be changed by clicking on it.

You can change the data format, the arbitration type and the baud rate in the configuration mode.

These settings will be permanently written to the CPAD2 modules. Also after power loss they will start on their new settings.

Error message counter:

The error counter indicates troubles on the CAN Bus. If the red number is permanently increasing instead of being zero, your CAN bus is unstable. In that case you normally also don't see any modules, or you miss a few.

- Check if the termination resistor is on the last CPAD node.
- Probably one CPAD is set to a different baud rate. Change the baud rate setting to different baud rates several times, and check if error message counter stops.
- Check the cabling. Probably your cable is too long for the baud rate. Try to reduce it.



Figure 3: Error message counter

CAN bus length:

- 1 Mbit/s: 30 m
- 800 kbit/s: 50 m
- 500 kbit/s: 100 m
- 250 kbit/s: 250 m
- 125 kbit/s: 500 m
- 50 kbit/s: 1000 m

Installing CPAD2 modules

Virtual CPAD2 modules

If you remove a CPAD from the CAN bus it will not disappear but change into the virtual mode. They could be still used in the setup but will not show any data. Immediately when you connect them again they will deliver data again. That even works in the measuring mode. Virtual modules could be added and removed with the buttons:

Remove:  Ad: 

That could be used for:

- Creating offline setups without the hardware.
- Creating a DBC file without the hardware.



Figure 4: Virtual CPAD2 modules

CPAD2 Channel Setup

Click on "CH. Setup" > "CAN" > "CANx" > "Ch. Setup"

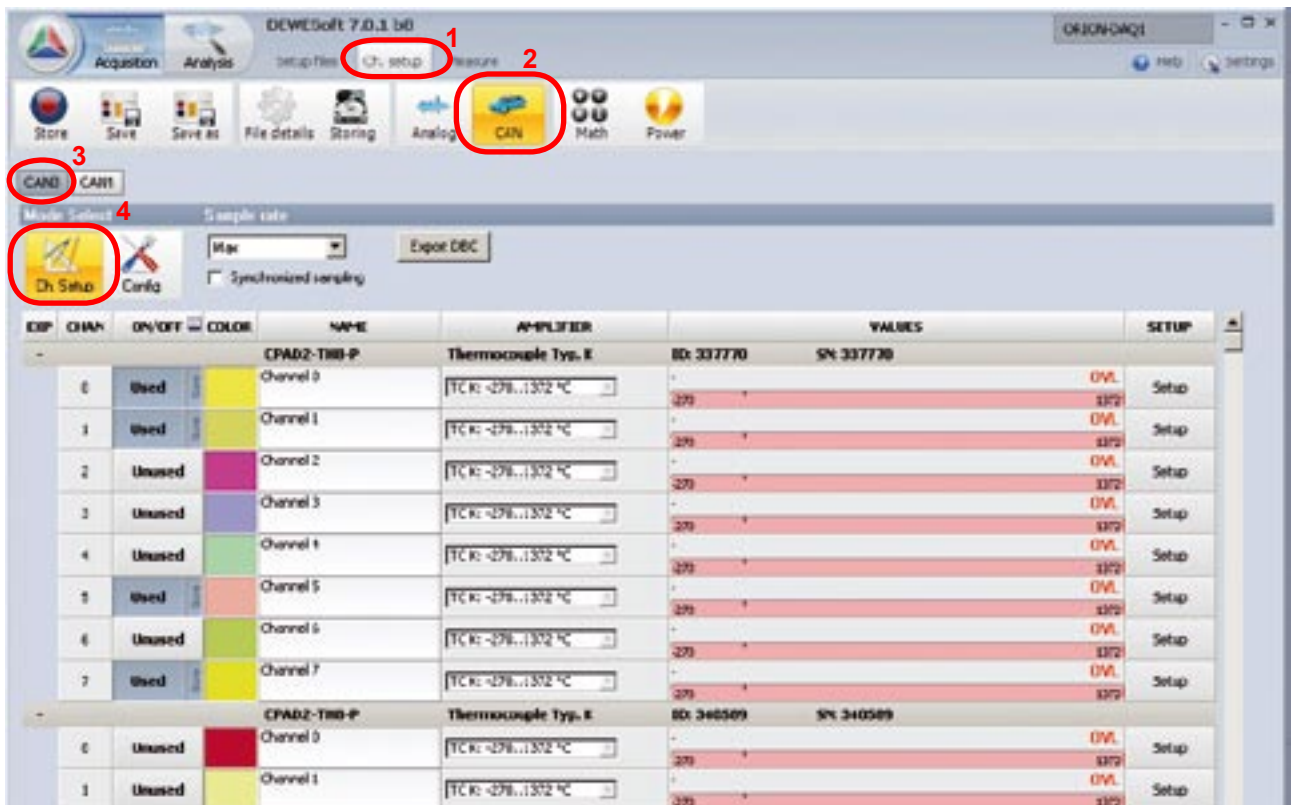

Figure 5: CPAD2 channel setup

Beside DEWESoft standard settings following, settings could be done in the channel setup:

- The sampling rate could be changed from 0.1 S/sec to max. Max means approximately 12.5 S/sec. The status LED flashes with the sample rate during measurement.
- If synchronized sampling is selected all CPAD2 modules acquire the data at the same time. Due to higher bus traffic only 5 S/second are possible in this mode.
- Exporting a DBC will create a DBC file with the actual CPAD2 configuration. This allows you to configure your CPAD2 modules and use them on an external CAN bus easily by importing the DBC file.

Installing EPAD2 modules

Installing EPAD2 modules in DEWESoft 7.x

Activate EPAD modules

Click on "Settings" > "Hardware Setup" > "Analog"

- Select the used COM port from the list
- Check PAD modules in the Amplifier list
- Select the amount of EPAD you want to connect

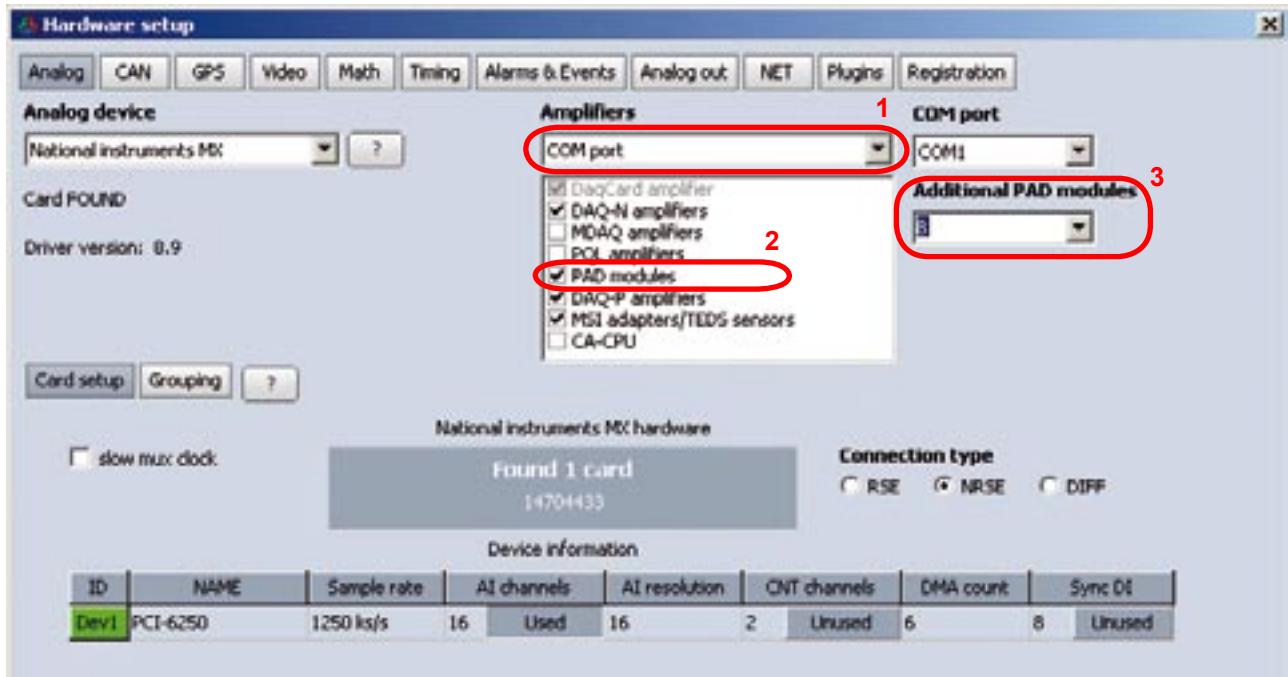

Figure 6: Activate EPAD modules

Assign module address

- Connect the first EPAD to the RS-485 bus.
- Double click in the amplifier column on the slot where you want to assign the EPAD module.
- Press the "Fill" button.

Now the EPAD status LED on all connected EPAD modules should flash. If not, they are probably on a wrong baud rate and a module reset has to be performed. It could also be that the wrong COM port is selected. Press on the ID button on the EPAD module which should be assigned. The EPAD should appear in the amplifier section. Connect the next EPAD and proceed in the same way.

Installing EPAD2 modules

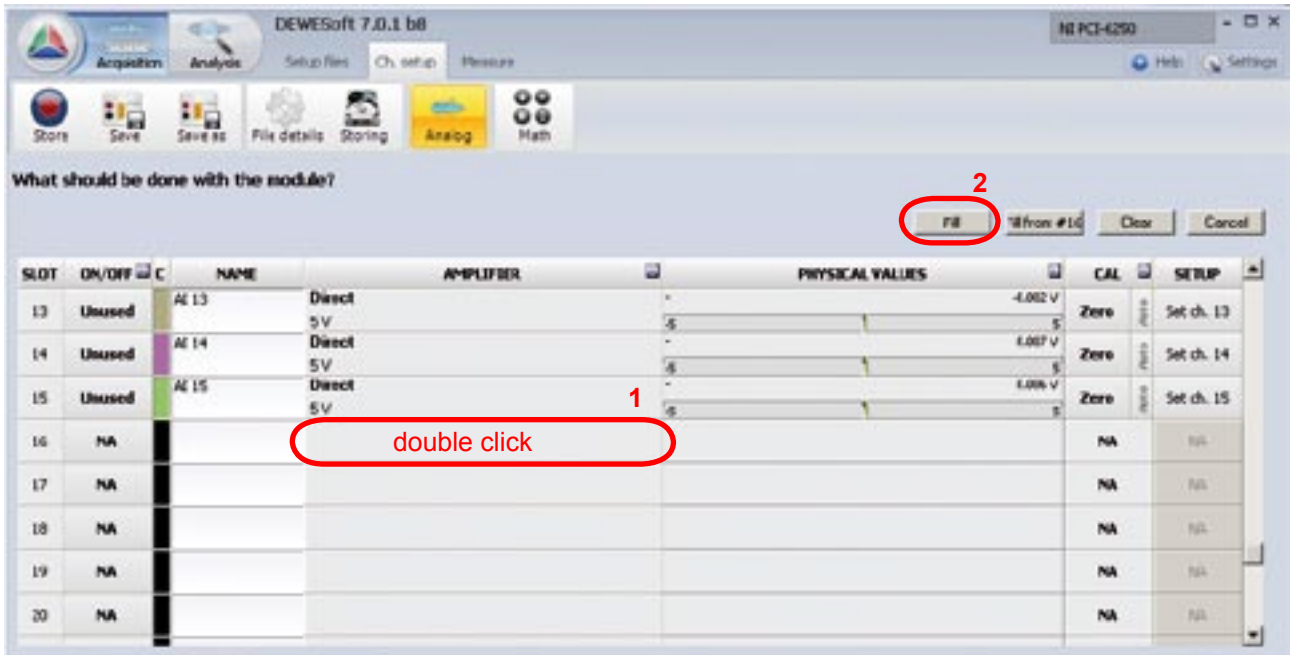

Figure 7: Assign module address

Connecting more than one unaddressed module to the RS485 bus at the same time is not recommended. It might be necessary to do the addressing several times until all modules are on the correct address. In that case it is recommended to press the ID button on the module before you click on the "Fill" button.

Found modules:

By clicking on "Set PAD" you have access to the eight channels of each module.

16	NA	EPAD-THB-P	SN: 00340589	1012	1012	1012	1012	NA	Set PAD 16
		TC K: -270.1372 °C		1012	1012	1012	1012		
17	NA	EPAD-THB-P	SN: 00337771	1012	1012	1012	1012	NA	Set PAD 17
		TC K: -270.1372 °C		1012	1012	1012	1012		

Figure 8: "Set PAD"

EPAD module setup

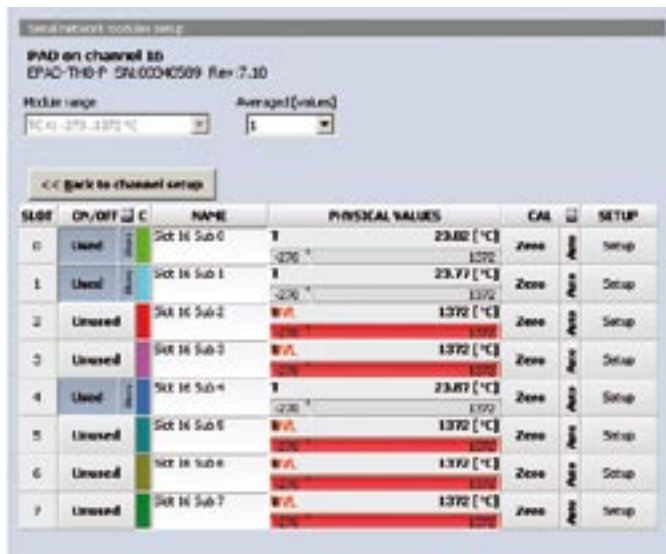

Figure 8: EPAD channel setup

Module reset

EPAD2 Module reset:

If the Module could not be detected from the software anymore a possible reason could be that the module has been set to a different address or baud rate. With the reset function you can set the module back to its default settings:

Baud rate: 9600 baud
Checksum: deactivated
Address: 0x00 (this equals a cleared module in Dewesoft)

Procedure: Press the ID button while powering on the module, and keep it pressed for at least 5 seconds.

CPAD2 Module reset:

If the module is not responding on the CAN bus anymore, or you have applied unwanted settings to the module it can be easily set to the default settings.

Identifier type: Extended
Data Identifier: Bit 29 to Bit 25 = 0
Bit 24 to Bit 1: = Module Serial Number
Bit 0: = ChnBit (0 for Channel 0 to 3; 1 for Channel 4 to 7)
Data Format: Intel
Baud Rate: 500 kbaud
Sample Rate: 1 Hz

Procedure: Press the ID button while powering on the module, and keep it pressed for at least 5 seconds. After that the module starts automatically measuring with 1Sample/Second. The status LED will indicate that by blinking with 1 Hz. The module will send the data of the eight channels with two identifiers that differ in the last bit.

Default Data Identifier Example:

Module Serial Number: 0341581

The module will send the data of channel 0 to 3 on identifier:

$341581 * 2 = 683162 = 0xA6C9A$

Data of channel 5 to 7 on identifier:

$341581 * 2 + 1 = 683163 = 0xA6C9B$

For detailed information how to change the identifier refer to the Programmers manual.

CAN bus length:

- 1 Mbit/s: 30 m
- 800 kbit/s: 50 m
- 500 kbit/s: 100 m
- 250 kbit/s: 250 m
- 125 kbit/s: 500 m
- 50 kbit/s: 1000 m

Mounting examples

The xPAD2 modules are prepared for various mounting options:

- DIN rail



- Cable strap



- Bolt down



For the mounting option "bolt down":
two screws with 4.2 mm diameter are required.

- Stack

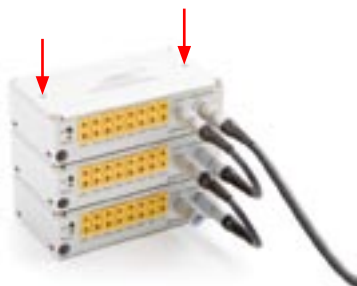

For the mounting option "stack":
two long M4 Allen head screws® are required.

Configuration examples

Configuration example with EPAD2 modules

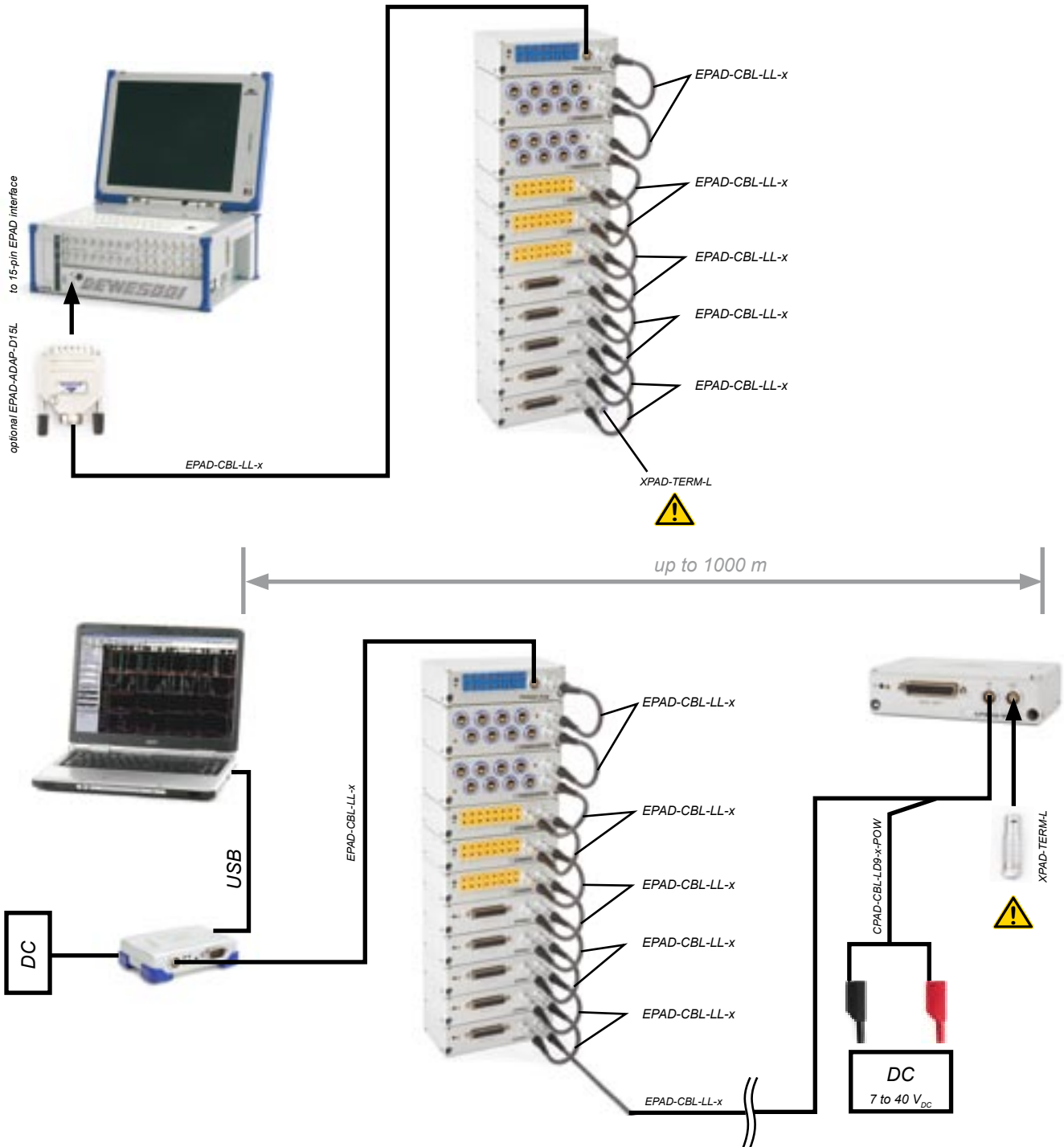

⚠ Note: In each case the last DEWE-xPAD2 module has to be terminated!

Note: Due to output resistance with longer cables an external DC power supply might be necessary. In this case, DEWETRON offers the CPAD-CBL-LD9-X-POW cable with two additional banana plugs for 7..40 V_{DC} power supply. Further information see chapter: Accessories & Options.

Configuration examples

Configuration example with CPAD2 modules

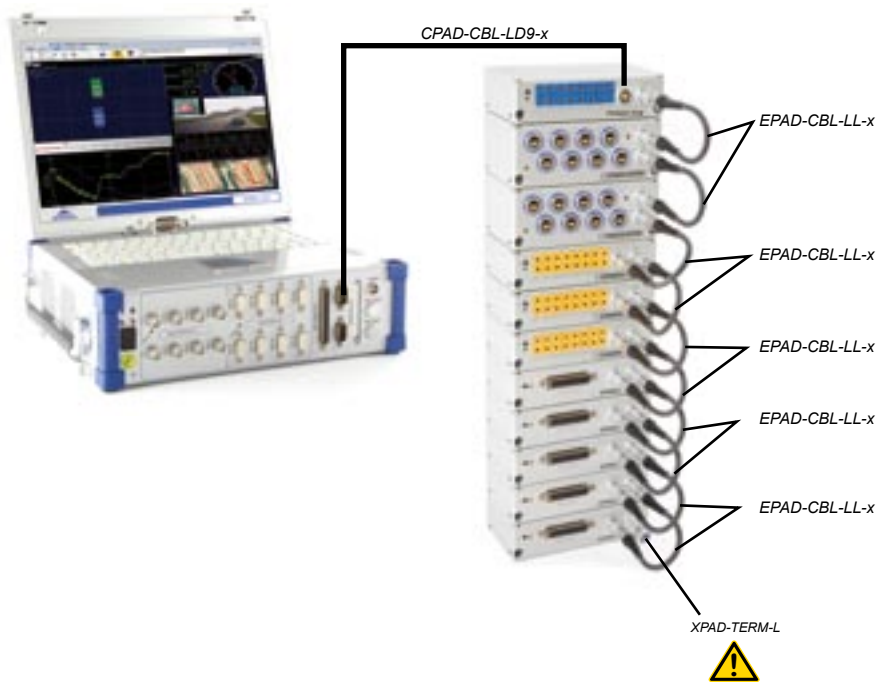

CAN bus length:

- 1 Mbit/s: 30 m
- 800 kbit/s: 50 m
- 500 kbit/s: 100 m
- 250 kbit/s: 250 m
- 125 kbit/s: 500 m
- 50 kbit/s: 1000 m

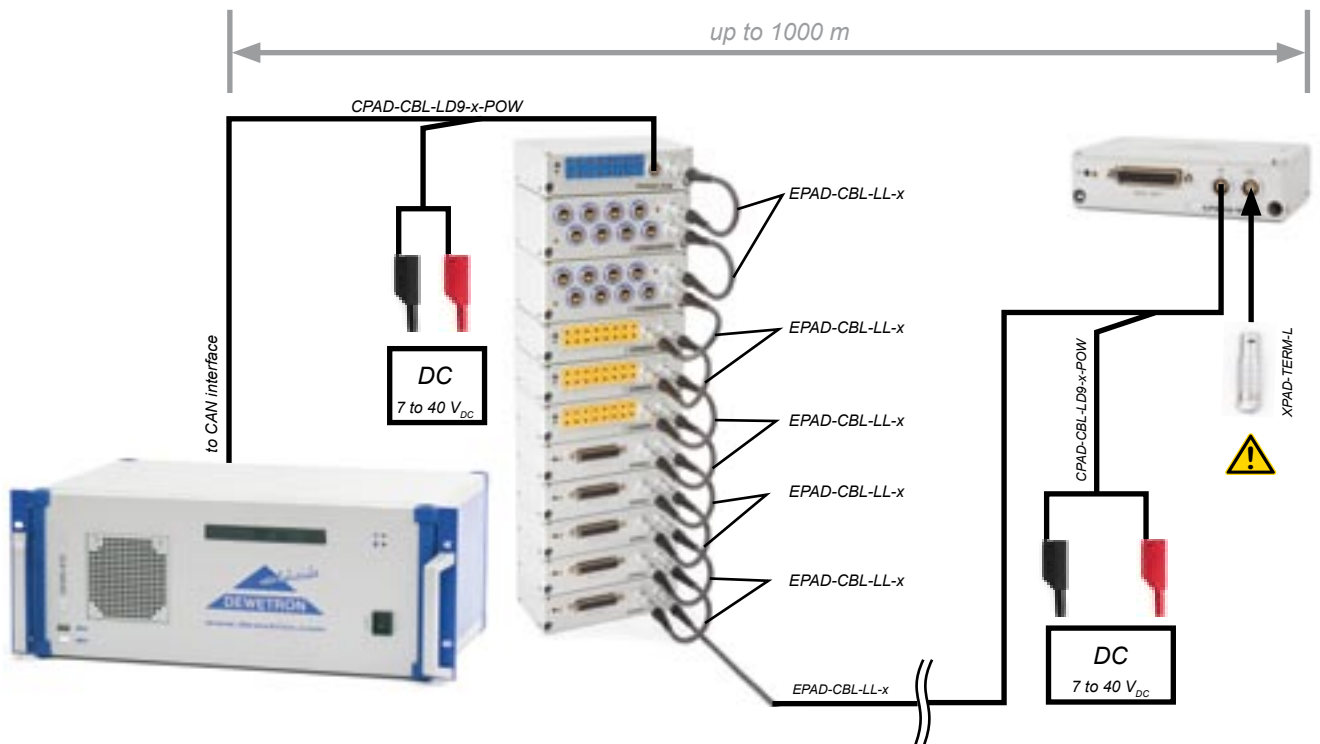

Note: In each case the last DEWE-xPAD2 module has to be terminated!

Note: Due to output resistance with longer cables an external DC power supply might be necessary. In this case, DEWETRON offers the CPAD-CBL-LD9-X-POW cable with two additional banana plugs for 7..40 V_{DC} power supply. Further information see chapter: Accessories & Options.

Accessories

Accessories & Options

General accessories and options for xPAD2 modules

EPAD-BASE2



Multifunction BASE module for

- connecting EPAD modules to USB - recognizes USB communication losses and reports them back to DEWESoft (native USB device, use with DEWESoft only!)
- connecting EPAD modules to RS-232
- transforming EPAD / PAD data to CAN

LEMO EGG.1B.304 socket for EPAD,

incl. external power supply 100 to 240 VAC / 15 VDC (for up to 16 EPAD modules)

XPAD-TERM-L



Termination connector for xPAD2 modules with Lemo EGG.1B.304 connector, the last module of the RS-485 bus must be terminated with this connector.

XPAD-CBL-LL-0.2



xPAD2 connecting cable 0.2 m with Lemo FGG.1B.304 connector on both sides, for daisy chaining stacked xPAD2 modules.

XPAD-CBL-LL-0.5



xPAD2 connecting cable 0.5 m with Lemo FGG.1B.304 connector on both sides, for connecting xPAD2 series modules to an instrument with Lemo EGG.1B.304 EPAD interface or to EPAD-BASE2 or for daisy chaining xPAD2 modules.

XPAD-CBL-LL-2



xPAD2 connecting cable 2 m with Lemo FGG.1B.304 connector on both sides, for connecting xPAD2 series modules to an instrument with Lemo EGG.1B.304 EPAD interface or to EPAD-BASE2 or for daisy chaining xPAD2 modules

XPAD-CBL-LL-5



EPAD2 connecting cable 5 m with Lemo FGG.1B.304 connector on both sides, for connecting EPAD2 series modules to an instrument with Lemo EGG.1B.304 EPAD interface or to EPAD-BASE2 or for daisy chaining EPAD2 modules

EPAD-ADAP-BL



Adapter cable 0.1 m, converts Binder 712-series plug to Lemo 1B.304 socket

- required to connect new xPAD2 modules to old instruments with Binder 712-series EPAD interface using EPAD-CBL-LL-x cables.
- required to connect EPAD modules with Binder 712-series connector to new instruments with Lemo EGG.1B.304 EPAD interface using EPAD-CBL-LL-x cables.

EPAD-ADAP-LB



Adapter cable 0.1 m, converts from Lemo 1B.304 plug to Binder 712-series socket

- required to connect existing EPAD modules with Binder 712-series connector to new instruments with Lemo EGG.1B.304 EPAD interface using existing EPAD-CBL-BB-x cables.

EPAD-ADAP-D15L



Adapter to convert EPAD interface from SUB-D-15 connector to Lemo 1B.304.

XPAD-DIN-RAIL



Adapter to snap EPAD2 and CPAD2 modules onto a DIN rail.

CPAD-CBL-LD9-2



Adapter cable 2 m to connect CPAD series modules to CAN interface, LEMO FGG.1B.304 plug to a SUB-D-9 socket, use only for DEWETRON systems with power supply on CAN connector.

CPAD-CBL-LD9-2-POW



Adapter cable 2 m to connect CPAD series modules to CAN interface, LEMO FGG.1B.304 plug to a SUB-D-9 socket, additional 2 banana plugs for module power supply.

PAD-OPT2

25-pin DSUB connector with screw terminal, for all PAD modules with 25-pin SUB-D socket, except xPAD2-TH8-P and xPAD2-TH8.

XPAD-OPT-EXT-TEMP

Extended operating temperature range from -40°C to +85°C for EPAD modules

Mating connectors for xPAD2-RTD8 and xPAD2-LA8 modules

LEMO-FFA.1S.304.CLAD42Z	LEMO FFA.1S.304 mating connector, cable diameter 3.1 to 4.0 mm
LEMO-FFA.1S.304.CLAD52Z	LEMO FFA.1S.304 mating connector, cable diameter 4.1 to 5.0 mm
LEMO-FFA.1S.304.CLAD62Z	LEMO FFA.1S.304 mating connector, cable diameter 5.1 to 6.0 mm

CE-Certificate of conformity



Manufacturer:

DEWETRON Elektronische Messgeraete Ges.m.b.H.

Address:

**Parkring 4
A-8074 Graz-Grambach Austria**

Tel.: +43 316 3070 0

Fax: +43 316 3070 90

e-mail: sales@dewetron.com

http://www.dewetron.com

Name of product:

DEWE-XPAD2 MODULES

Kind of product:

Modules

The product meets the regulations of the following EC-directives:

73/23/EEC

"Directive on the approximation of the laws of the Member States relating to electrical equipment designed for use within certain voltage limits amended by the directive 93/68/EEC"

89/336/EEC

"Directive on the approximation of the laws of the Member States relating to electromagnetic compatibility amended by the directives 91/263/EEC, 92/31/EEC, 93/68/EEC and 93/97/EEC"

The accordance is proved by the observance of the following standards:

L V E M C	Safety	IEC/EN 61010-1:1992/93 IEC/EN 61010-2-031	IEC 61010-1:1992/300 V CATIII PoI. D. 2 IEC 1010-2-031
	Emissions	EN 61000-6-4	EN 55011 Class B
	Immunity	EN 61000-6-2	Group standard

Graz, October 14, 2008

Place / Date of the CE-marking

Dipl.-Ing. Roland Jeutter / Managing director

Notes
